

INSTALLATION AND OPERATING MANUAL

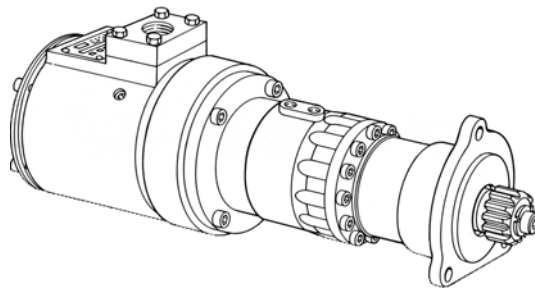

MODEL: T50-Y **TURBOTWIN** Engine Air Starter

AIR ONLY

TABLE OF CONTENTS

Section	Subject	Page
1.0	General Information.....	1
2.0	Orientation of the Starter.....	1
3.0	Installing the Starter.....	2
4.0	Starter Operation.....	3
5.0	Warranty.....	4
6.0	Operator's Troubleshooting Guide.....	5

LIST OF ILLUSTRATIONS

Figure	Title	Page
1	T50-Y Air Starter (Dimensional Data)..	6
2	T50-Y Installation Diagram.....	7
3	Performance Curve (10 Nozzle).....	8
4	Performance Curve (14 Nozzle).....	9

1.0 GENERAL INFORMATION

This manual provides instructions for the installation and operation of the TDI **TURBOTWIN**™ Model T50-Y engine air starters. If there are questions not answered by this manual, please contact your TDI **TURBOTWIN**™ distributor or dealer for assistance.

The Model T50-Y is a turbine driven air starter with a pre-engage starter drive. It is well suited for starting diesel engines up to 70 Liters (4270 CID) or gasoline engines up to 98 Liters (5978 CID). The Model T50-Y is designed for installation on engines which use an SAE 1, 2, or 3 mounting pad.

The T50 Series starters are suited to operate within a wide range of inlet air pressures and ambient temperatures. The engine size and parasitic loading will determine the exact minimum pressure that will ensure reliable starting.

The T50 Series starters are designed for operation with compressed air. Small to moderate amounts of foreign matter or liquid in the air stream will normally not adversely affect T50 Series starters. As with all other TDI **TURBOTWIN**™ models, no lubrication is required in the supply air.

You need to review the rest of this manual before installing your TDI **TURBOTWIN**™ T50-Y Series starter.

1.1 WARNINGS, CAUTIONS, & NOTES

Throughout this manual, certain types of information will be highlighted for your attention:

WARNING - used where injury to personnel or damage to the equipment is likely.

CAUTION - used where there is the possibility of damage to the equipment.

NOTE - used to point out special interest information.

1.2 INSTALLATION and SERVICE

The TDI **TURBOTWIN**™ T50 Series starters provide distinct advantages of size and efficiency compared to electric motor, vane-type or other turbine-type air starters. It is important to properly install the starter to receive full benefit of these advantages. Repair technicians or service organizations without turbine starter experience should not attempt to repair this starter until they receive factory approved training from TDI, or its representatives. Proper operation and repair of your TDI **TURBOTWIN**™ T50 Series starter will assure continued reliable and superior performance for many years.

WARNING

The TDI **TURBOTWIN**™ T50 Series starter must be installed and operated in accordance with the instructions given in this manual. Failure to properly install the starter, or failure to operate it according to these instructions may result in damage to the starter or the engine, or cause personal injury.

NOTE

THIS STARTER IS TO BE SERVICED ONLY BY AUTHORIZED TDI **TURBOTWIN**™ DISTRIBUTORS, DEALERS, AND REPAIR STATIONS. DO NOT OPERATE THIS STARTER UNLESS IT IS PROPERLY ATTACHED TO AN ENGINE.

2.0 ORIENTATION OF THE STARTER

If the factory orientation of the starter's pinion housing, gearbox assembly, or optional exhaust port does not fit your engine installation, the starter can be re-oriented.

2.1 MODEL T50-Y ORIENTATION

A. Determine the required orientation of the pinion housing and gearbox housing.

B. Note that the pinion housing can be rotated to twelve different positions relative to the gearbox housing and the gearbox housing can be rotated to four positions relative to the inlet port.

TDI TURBOTWIN™

FROM TECH DEVELOPMENT, Inc

CAUTION

All screw threads are treated at the factory with a fastener retention compound. Every screw and tapped hole must be clean and have a drop of Loctite 290 applied to the threads before being reinstalled.

2.1.1 Pinion Housing Re-Orientation

Remove the twelve pinion housing to gearbox housing socket head cap screws.

Rotate the pinion housing to the desired position and reinstall the twelve cap screws. Torque the twelve socket head cap screws to **12 Lb-Ft (16.9 Nm)**.

CAUTION

Ensure that the O-ring on the pinion housing remains in position and is not cut.

2.1.2 Gearbox Housing Re-Orientation

Remove the four tie bolts that secure the gearbox housing to the inlet housing.

Rotate the gearbox/pinion housing to the desired position.

CAUTION

Ensure that the O-rings between the gearbox housing ring gear and inlet/turbine assembly remain in position and are not cut.

Reinstall the four tie bolts. Torque the four tie bolts to **12 Lb-Ft. (16.9 Nm)**.

3.0 INSTALLING THE STARTER

Typical T50 Series installations are shown in Figure 2. The components illustrated may vary in shape, but there must at least be a start switch, air tank, and air piloted relay valve to correctly install and operate a T50 Series starter.

NOTE

Mounting the air piloted relay valve on the starter is preferred in non-vehicle installations

TDI recommends mounting the air piloted relay valve no more than 3 meters (10 feet) from the starter's inlet port, and as close to the starter as possible. If the starter is being installed on a vehicle where the air tank is within 3 meters (10 feet) of the starter, then the relay valve may be mounted on the tank.

A turbine driven starter does not require lubrication in the supply air. Therefore, if a vane-type starter motor is being replaced, TDI recommends all lubrication devices and lines be removed to minimize flow restrictions.

WARNING

If a fuel (pulse) lubricator has previously been installed in the system, disconnect and plug the line to eliminate spraying diesel fuel on the engine.

Liberal grease the starter's pinion teeth with chassis lube and then mount the T50 Series starter on the engine. Tighten all mounting hardware as appropriate.

After mounting the starter to the engine, attach the supply air line from the tank, the control air lines, and the solenoid to the ignition system and air piloted relay valve.

TDI recommends installation of a "Glad Hand" / quick disconnect for auxiliary pressurization of the air tank.

Because turbine starters such as the T50 Series are sensitive to flow restrictions, care must be taken to use uniform hose or tubing and fittings for connection of the supply air line. Tees, elbows, and line length must be kept to a minimum. TDI recommends hose or flex couplings be installed to eliminate strain on the supply air line.

Normally an air strainer is not required. In dirty environments, use of a #40 mesh Y-strainer is recommended.

WARNING

Recheck all connections for tight fit.

Fill the air system tank. The T50-Y Series starter is now ready to operate.

4.0 STARTER OPERATION

The maximum operating pressure limit noted on the starter's nameplate is the pressure measured at the starter inlet pressure check port. In order to check the starter inlet pressure, an 1/8" NPT pipe tap connection is provided on the housing. To attach a pressure gauge; refer to Figure 1.

CAUTION

IN NO CASE SHOULD INLET OPERATING PRESSURE EXCEED 10.3 BAR (150 PSIG).

WARNING

Do not operate the TDI *TURBOTWIN* T50 Series air starter with air pressure greater than the pressure rating on the nameplate. This pressure is to be measured at the starter inlet while the starter is running.

The static supply pressure will always be higher than the operating pressure. As a guideline, the maximum pressure limit (proof pressure) the T50 Series starter may be subjected to is 20.7 bar (300 PSIG). System pressure that exceeds the maximum operating limit must use a pressure reducer device to ensure that the operating pressure limit to the T50 Series starter is maintained.

All appropriate local pressure codes and pressure limitations on other system components must be adhered to and supersede the guidelines given in this manual.

Follow the engine manufacturer's instructions for starting the engine.

WARNING

Do not engage the starter while the engine is running.

If the starter fails to function properly when first operated, or its performance deteriorates with use, refer to the Operator's Trouble Shooting Guide, Section 6.0. If you cannot solve the problem, or repair is necessary, contact your local TDI *TURBOTWIN*[™] distributor or dealer.

TDI turbine starters share a common characteristic known as "coast-down". Once unloaded, turbines must coast to a stop from their unloaded or *free-speed*. Turbines behave differently in this respect, when compared to positive displacement devices, because the friction (drag) of rubbing, sealing surfaces (piston rings or vanes) quickly stops an unloaded machine. Less encumbered by drag, and typically decelerating from much higher operating speeds, turbines can take longer to come to rest.

When pre-engaged starters are used, a procedure specifying a 30-second delay between engine crank attempts would be sufficient to insure correct operation. This is common practice and such delays are typically programmed into fully automated starter control systems found on many packages. This "**30 Second Rule**" should also be strictly followed when using the starter in a "manual mode" or when performing routine maintenance tasks such as engine timing, inspections, valve adjustments, etc.

WARNING

Re-engaging pre-engaged turbine starters during coast-down can damage the starter pinion and the engine ring gear. Turbine air starters must **NEVER** be re-engaged during coast-down or before the starter comes to a complete stop.

To insure correct starter operation, an electronic control device (P/N: 2-28582) can be incorporated in the control system to prevent accidental re-engagement during coast-down.

TDI TURBOTWIN™

FROM TECH DEVELOPMENT, Inc

5.0 WARRANTY

TDI TURBOTWIN ENGINE STARTER WARRANTY

Tech Development Inc. (TDI) warrants to the original user of the TDI TURBOTWIN™ Model T50 Series air starters to be free from defects in material and workmanship for a period of one year from the date of installation. The warranty period shall not extend beyond two years from the date the unit was manufactured. (i.e.: a unit with a manufactured date of July 1999 (SN: 9907-101) will not be covered under warranty after July 2001). The conditions of this warranty are: **a)** TDI is notified within this period by return of such product to TDI or its authorized distributor/dealer, transportation prepaid by user; **b)** the starter has been installed according to TDI's specifications; **c)** the starter has not been misused, abused, or improperly maintained by user; **d)** the defect is not the result of normal wear and tear; **e)** the starter has been repaired with parts manufactured or authorized by TDI; and **f)** TDI installation and repair procedures as outlined in the appropriate manual were properly followed.

Tech Development Inc. will repair, or at its option, replace the unit during the warranty period at no charge to the customer, provided it is returned to TDI with the proper return procedure.

Tech Development Inc. makes no other warranty, and implied warranties including any warranty or merchantability or fitness for a particular purpose are hereby disclaimed.

This warranty constitutes the entire obligation of Tech Development Inc. relating to the sale and use of such product, and TDI's maximum liability is limited to the purchase price of such product at the date of purchase. In no event shall TDI be liable for incidental, indirect, consequential, or special damages of any nature arising from the sale or use of such engine starter product.

6.0 OPERATOR'S TROUBLESHOOTING GUIDE

TROUBLE	PROBABLE CAUSE	SOLUTION
1. Air always flow through exhaust	A. Relay valve improperly installed.	A. Check typical installation diagram and correct.
	B. Relay valve not sealing properly.	B. Check for damaged sealing ring, replace relay valve or damaged parts.
	C. Solenoid is not sealing, pressure remains in APP port of relay valve.	C. Check solenoid potential at the lead to ground, should be 0. If not, fix ignition switch problem.
2. Starter engages but does not run,	A. Bad relay valve	A. Replace relay valve.
3. Starter does not run, small air flow from turbine exhaust or drive housing.	A. Nozzle blockage.	A. Remove blockage or obstruction from nozzles.
4. Starter does not run. Normal air flow from exhaust.	A. Excessive bends in the supply line.	A. Shorten length or straighten supply air line.
5. Pinion does not engage	A. Air pressure is too low	A. Increase air pressure to 150 - 40 psig.
	B. Control lines to starter ports reversed.	B. Check installation diagram and correct.
	C. Solenoid valve not operating or plugged.	C. Check wiring and solenoid operation. Correct wiring, remove blockage, or replace solenoid valve as needed.
	D. Damaged pinion teeth.	D. Replace pinion or starter drive as necessary.
6. Starter runs but engine cranks slowly or not at all.	A. Air pressure too low	A. Increase air pressure to 150-40 psig.
	B. Excessive back pressure.	B. Check Exhaust Closure Plate.
	C. Nozzle blocked or damaged.	C. Remove blockage or replace damaged parts.
7. Starter continues to operate after start button is released.	A. Solenoid valve is not sealing correctly.	A. See 1C. above
	B. Relay valve is not sealing correctly.	B. See 1B. above
8. Air tank pressure decays after extended shut down.	A. Air connections are not tight.	A. Tighten loose fittings. Repair or replace damaged fittings.
	B. Damaged air lines: crushed, frayed, and kinked.	B. Replace damaged lines.
	C. Relay valve is not sealing correctly.	C. See 1B. above
	D. Solenoid valve is stuck open.	D. A. See 1C. above

TDI TURBOTWIN™

FROM TECH DEVELOPMENT, Inc

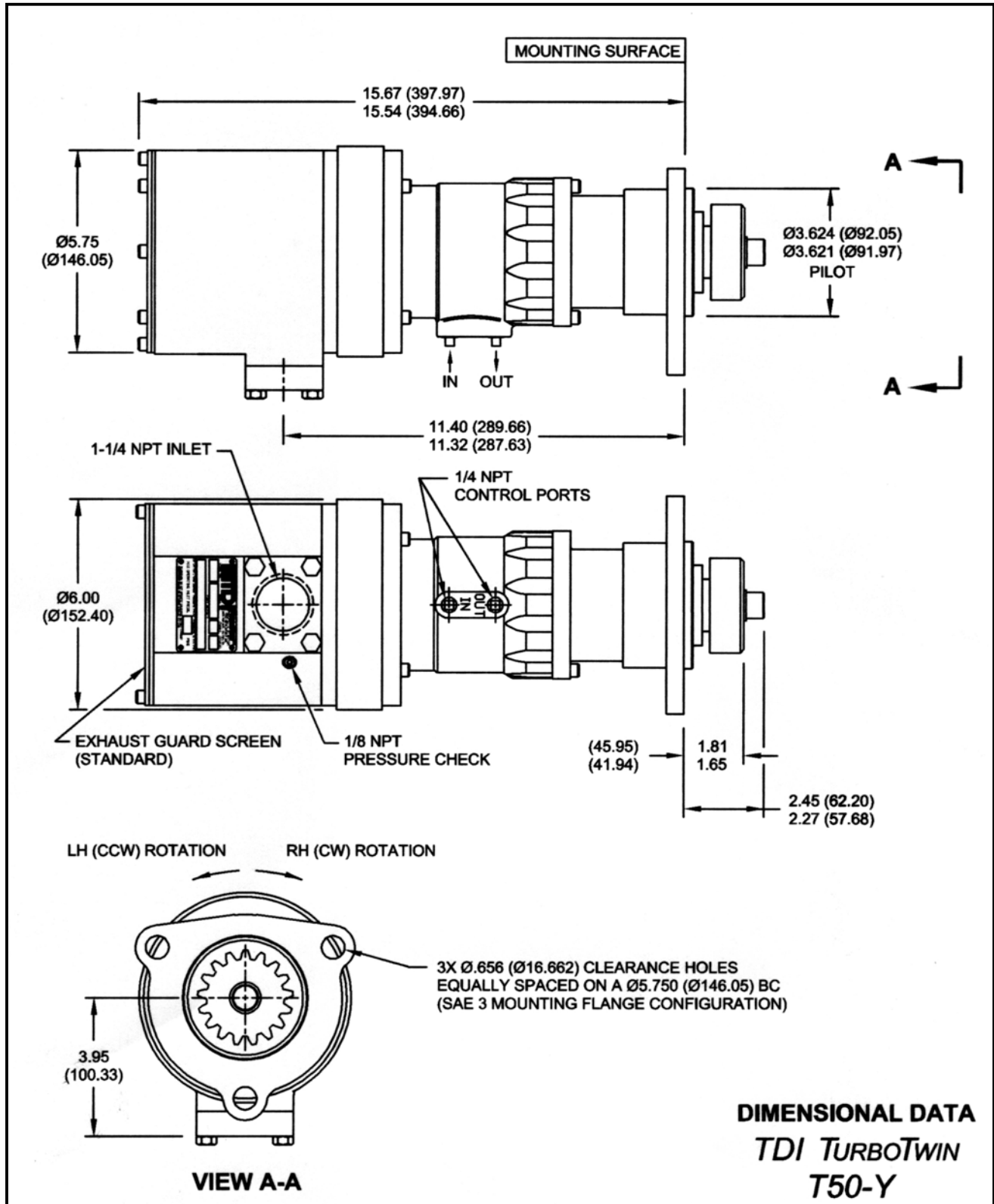

Figure 1. T50-Y TURBOTWIN Air Starter

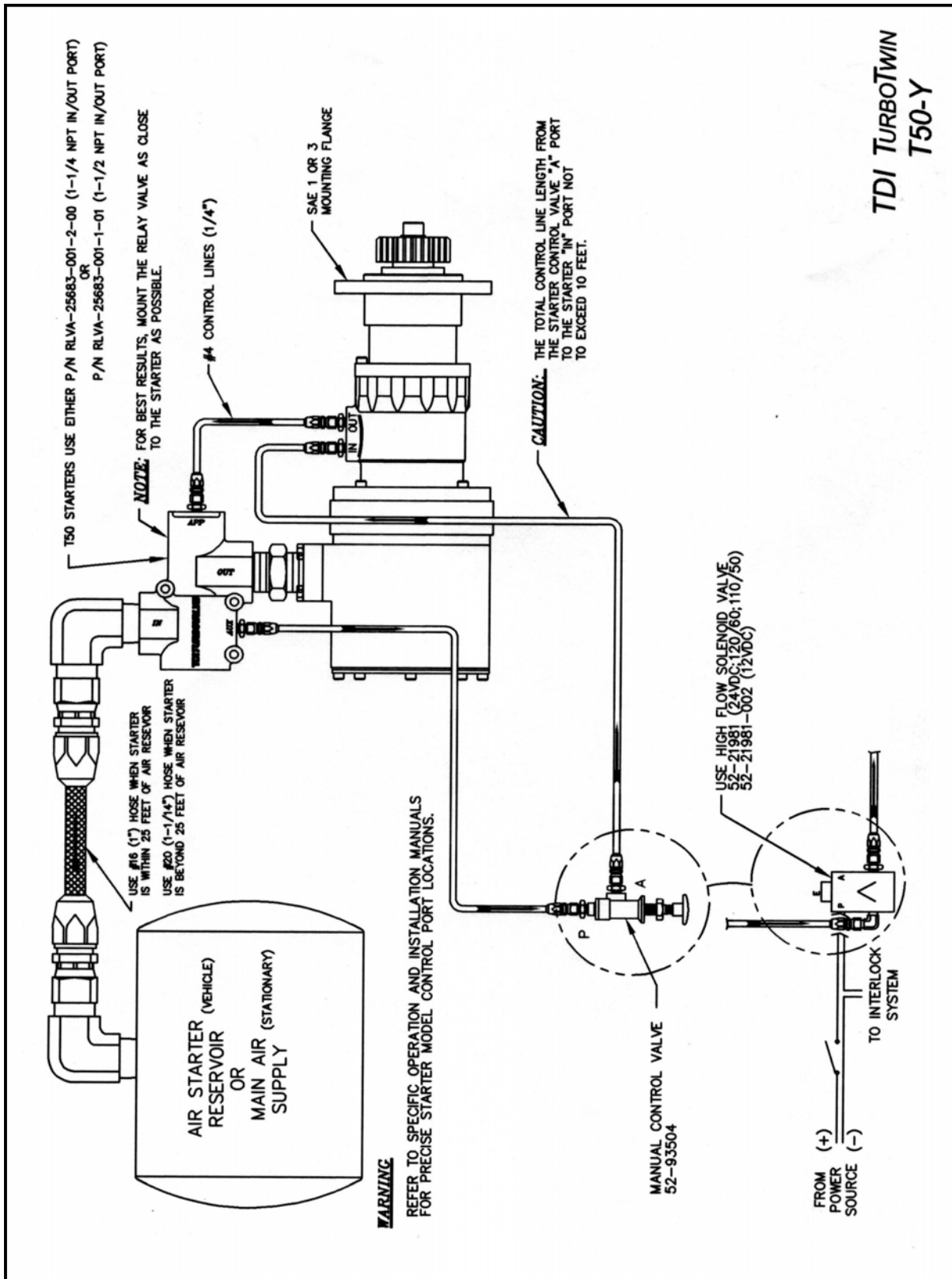

Figure 2. T50-Y Installation Diagram

TDI TURBOTWIN™

FROM TECH DEVELOPMENT, Inc

Model: T50-Y (10 Nozzle, Compressed Air, 11.2:1)

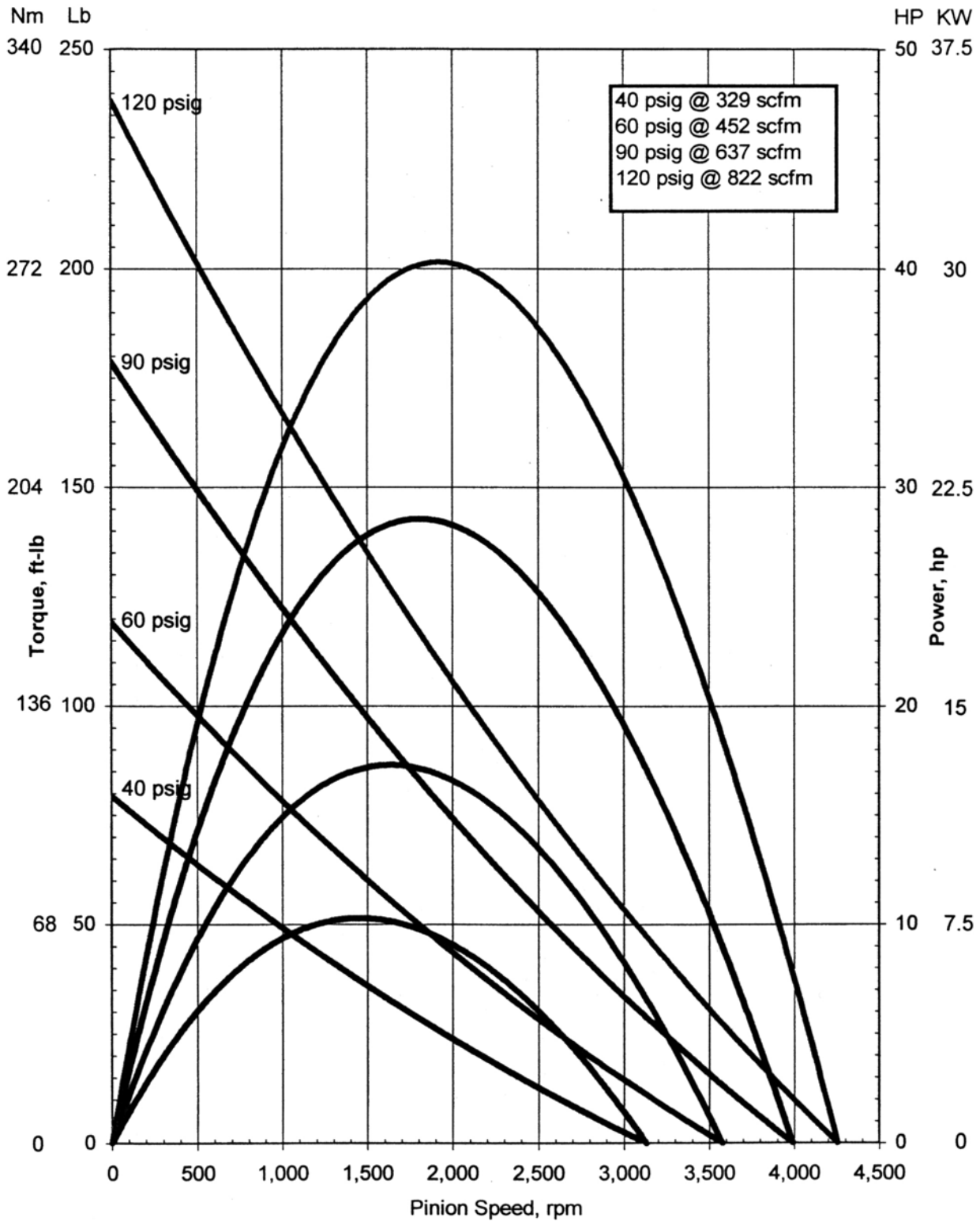

FIGURE 3

TDI TURBOTWIN™

FROM TECH DEVELOPMENT, Inc

Model: T50-Y (14 Nozzle, Compressed Air, 11.2:1)

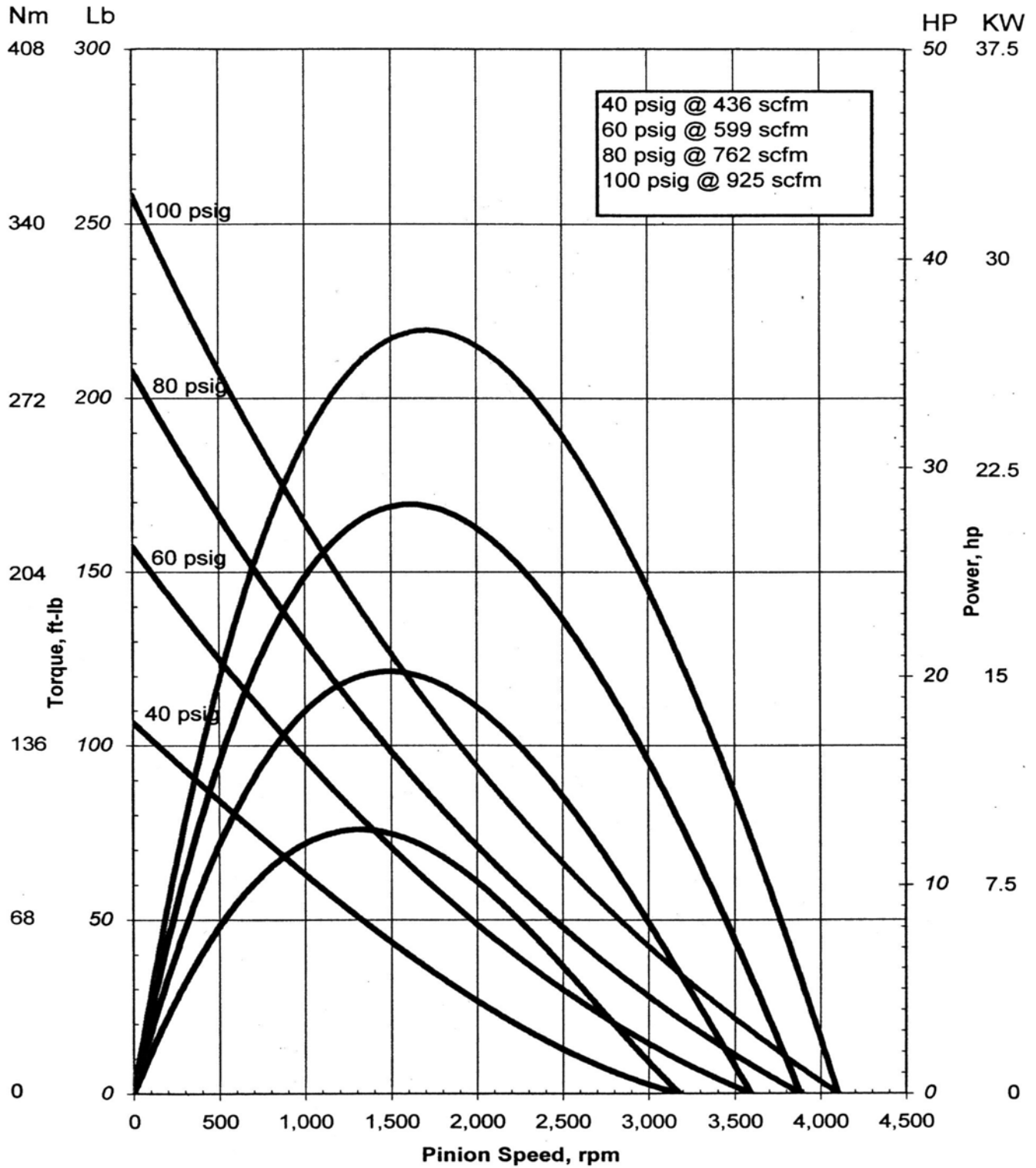

FIGURE 4